

SCREW CONVEYOR



PrimeMove™
COZZINI MATERIAL HANDLING SYSTEMS

SCREW CONVEYOR

- Unique, quick-release, watertight shaft seals for full washdown sanitation.
- Standard screw auger dimensions: Ø6" (152 mm) to Ø30" (762 mm) diameter.
- Safety gratings and safety interlocks.
- Available in your choice of two, three or four position power pivots, as well as portable or stationary designs.
- Optional telescoping legs lower conveyor for cleaning.
- Optional hopper agitator to prevent product bridging.
- Custom designed hopper sizes, dump heights, and incline positions.
- USDA accepted and CE approved. Built in conformity with AMI sanitary equipment design principles.

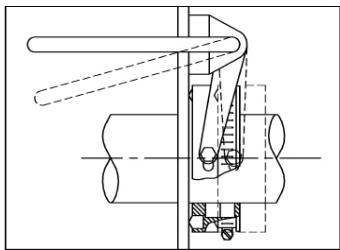

Watertight shaft seals

SCREW CONVEYOR

Cozzini knows that reliable material handling is a critical part of your overall process. That is why Cozzini Screw Conveyors (CSC) are custom-made to meet your demanding production requirements. Choose from a multitude of auger diameters, drive speeds, hopper capacities, pivots and discharge heights. Optional casters allow portability.

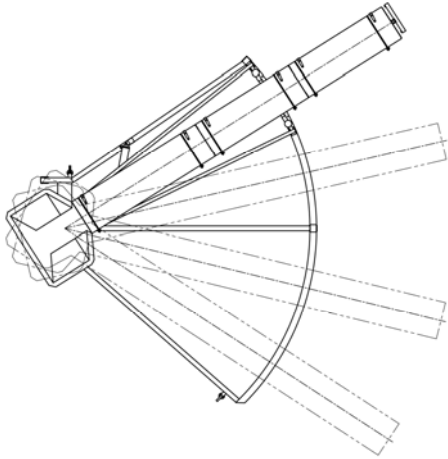

Sanitation and cleanability are just as important. Stainless steel construction with fine sanitary finish throughout, and smooth-ground welds in all product contact zones ensure utmost sanitation and ease of washdown and inspection. Hinged covers, quick-release seals, and washdown duty motors make the CSC series a standalone among other screw conveyor designs.

Call Cozzini for fast, dependable solutions to all your conveyor/material handling needs.

4-station pivoting screw conveyor

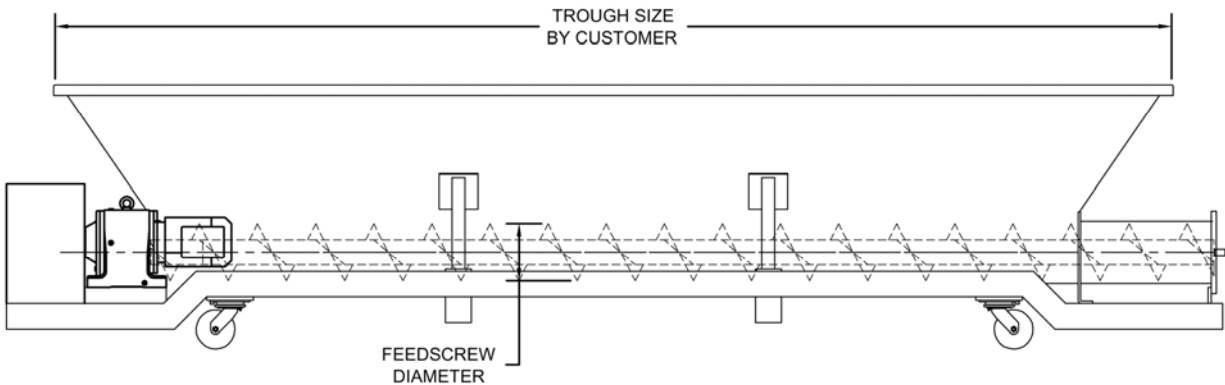

Horizontal screw conveyor

10/05 E

WORLD HEADQUARTERS Cozzini, Inc.
4300 West Bryn Mawr Avenue Chicago, IL 60646-5943 U.S.A

COZZINIGROUP
COMPLETE FOOD EQUIPMENT SOLUTIONS

WORLD REPRESENTATION • 773 478-9700 • www.cozzini.com • sales@cozzini.com