

MIXER/BLENDER

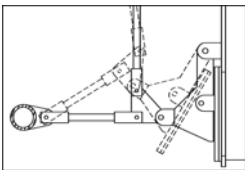

PrimeMix™ COZZINI MIXING SYSTEMS



Unique, over-center discharge door locking system assures closure during utility interruptions.

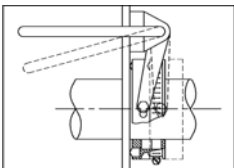

Unique, quick-release, watertight shaft seals for full washdown sanitation.

MIXER/BLENDER

- Grating or lid-style cover designs available.
- Standard or fully programmable Allen-Bradley controls.
- Optional paddle designs include paddle-style (standard or overlapping) or ribbon-style agitators. Overlapping paddle design requires bottom discharge.
- Capacities from 100 lbs. (45 kg) to 15,000 lbs. (6800 kg).
- USDA accepted and CE approved. Built in conformity with AMI sanitary equipment design principles.

MIXER/BLENDER

Cozzini Mixer/Blenders (CMB) series units are designed for heavy-duty use and built to last for many years. Very few wear parts keep them very economical to use and maintain.

The CMB series is used worldwide for numerous mixing/blending applications such as meat preblends, ground meat operations, formulation mixing of ingredients for cereals, spices, vegetables, etc. For applications requiring precise temperature control, glycol jacketing or CO₂ injection cooling systems are available.

The CMB series ensures high volume throughput, loading and unloading efficiencies.

High quality, stainless steel construction with fine sanitary finish throughout.

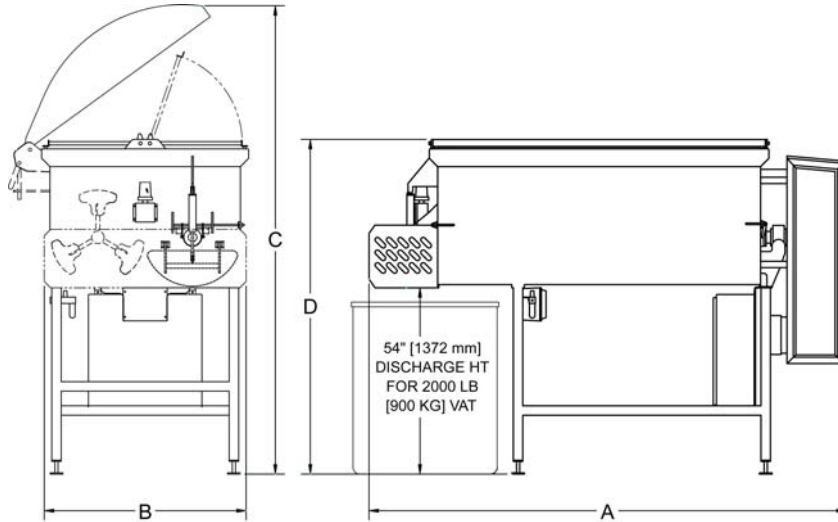

MIXER/BLENDER											
DIMENSION*		A (length)		B (width)		C (open ht.)		D (top of tub)		DRIVES	
Lbs	kg	inch	mm	inch	mm	inch	mm	inch	mm	hp	kW
100	45	<i>Lab mixer sized per customer specifications</i>									
500	225	88	2235	50	1270	82	2083	58	1473	2	1.5
750	350	90	2286	52	1321	86	2184	85	2159	3	2
1000	450	103	2616	50	1270	95	2413	85	2159	3	2
1500	700	105	2667	67	1702	131	3327	85	2159	5	4
2000	900	121	3073	62	1575	118	2997	89	2261	7.5	6
2500	1000	118	2997	60	1524	123	3124	93	2362	7.5	6
3000	1400	140	3556	70	1778	139	3531	92	2337	10	8
4000	1800	140	3556	73	1854	123	3124	99	2515	15	11
5000	2300	154	3912	74	1880	141	3581	98	2489	20	15
6000	2700	154	3912	76	1930	126	3200	102	2591	20	15
8000	3600	167	4242	80	2032	124	3150	103	2616	30	22
10,000	4500	171	4343	88	2235	134	3404	107	2718	40	30
12,500	5700	192	4877	87	2210	133	3378	114	2896	50	38
15,000	6800	<i>Mixer sized per customer specifications</i>									

*Dimensions can vary based on customer requirements or modifications to equipment

10/05 E

WORLD HEADQUARTERS Cozzini, Inc.
4300 West Bryn Mawr Avenue Chicago, IL 60646-5943 U.S.A

COZZINIGROUP
COMPLETE FOOD EQUIPMENT SOLUTIONS

WORLD REPRESENTATION • 773 478-9700 • www.cozzini.com • sales@cozzini.com