

VACUUM MASSAGER/MIXER STYLE

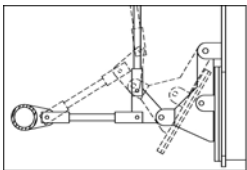

FastHam[®]
COZZINI CONTINUOUS HAM PROCESS



Unique, over-center discharge door locking system assures closure during utility interruptions.

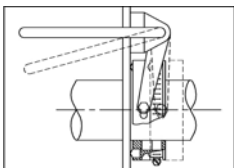

Unique, quick-release, vacuum-tight shaft seals for full washdown sanitation.

VACUUM MASSAGER/MIXER STYLE

- Lower massage times. Reduce or eliminate holding times.
- Gentle or aggressive massaging action with hydraulic or electric variable speed agitators.
- Standard or fully programmable Allen-Bradley controls.
- Quick and easy vacuum loading.
- Capacities from 2200 lbs. (1000 kg) to 20,000 lbs. (9100 kg).
- USDA accepted and CE approved. Built in conformity with AMI sanitary equipment design principles.

VACUUM MASSAGER/MIXER STYLE

When a vital step in the production of your whole muscle product includes vacuum massaging, insist on a Cozzini Vacuum Massager/Mixer Style (CVMM) series unit, customized to fit your exact needs. The CVMM series of massagers offers you the versatility, throughput and control you need for superior appearance, flavor, texture and yield in your finished products while maintaining high volume production.

The Cozzini Vacuum Massager addresses the critical issue of temperature control with two cooling systems: glycol jacketing or CO₂ injection. Besides glycol jacketing in the walls of the CVMM tub, Cozzini's special ribbon agitator design permits glycol to be circulated within the agitator, greatly increasing cooling capacity. The unique agitator design assures optimum cure distribution and penetration.

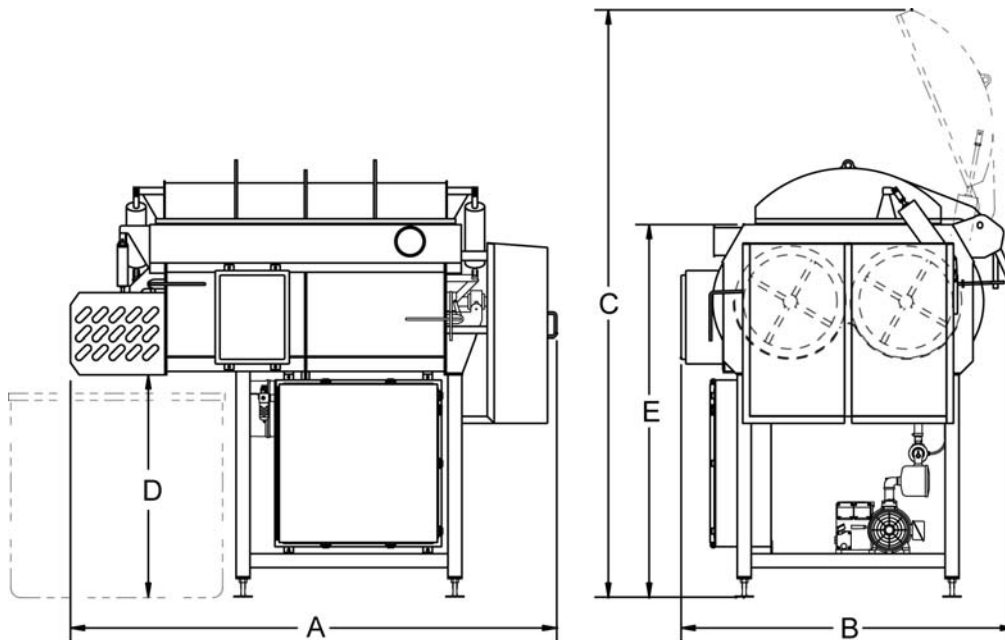

FASTHAM VACUUM MASSAGER

Capacity*		A (Length)		B (Width)		C (Open lid ht.)		D (Discharge ht.)		E (Top of tub)		Drive Motors (2)	
Lbs.	kg	Inch	mm	Inch	mm	Inch	mm	Inch	mm	Inch	mm	HP	kW
2,200	1,000	105	2,667	66	1,854	127	3,220	48	1,219	81	2,057	3	2
3,500	1,600	138	3,505	72	2,108	133	3,366	50	1,270	88	2,235	5	4
5,000	2,300	138	3,505	75	2,134	137	3,480	50	1,270	90	2,286	7.5	6
6,000	2,750	150	3,810	84	2,137	148	3,760	50	1,270	92	2,336	10	7.5
8,000	3,650	170	4,318	86	2,185	153	3,886	50	1,270	96	2,438	10	7.5
10,000	4,550	168	4,267	90	2,286	158	4,013	60	1,524	106	2,692	15	11
12,000	5,450	188	4,775	94	2,388	172	4,369	60	1,524	109	2,768	20	15
13,500	6,150	193	4,978	98	2,489	179	4,547	60	1,524	114	2,895	25	19
20,000	9,100	246	6,248	106	2,693	230	5,842	113	2,870	169	4,292	30	23

*Capacities are based on 60 lbs/ft³ (960 kg/m³) density.

10/09 E

WORLD HEADQUARTERS Cozzini, Inc.
4300 West Bryn Mawr Avenue Chicago, IL 60646-5943 U.S.A

COZZINIGROUP
COMPLETE FOOD EQUIPMENT SOLUTIONS

WORLD REPRESENTATION • 773 478-9700 • www.cozzini.com • sales@cozzini.com