

HE2 KNIFE SHARPENING SYSTEM



Shown with optional cart.

PRIMEEdge®
COZZINI CUTTING EDGES
AND SHARPENING SOLUTIONS



**Grinding
stones**

**Honing
stones**

HE2 KNIFE SHARPENING SYSTEM

- All-in-one unit with grinding and honing stones.
- Unique spiral-shaped honing/edging stones design assures consistent, smooth, sharp edges.
- Sharpens blades up to 14" (356 mm) long.
- Recirculating liquid coolant system provides burn-free and dust-free operation.
- Integrated stone dressing system maintains roundness of the stones for perfect, consistent, sharp edges.
- Optional cart available.
- CE approved.

HE2 KNIFE SHARPENING SYSTEM

Ideal for smaller meat processors, supermarkets, hardware stores and sharpening services, the compact Cozzini HE2 provides the same benefits as the larger capacity Cozzini sharpening systems utilizing separate hollow grinding and honing/edging units.

The Ø4" (102 mm) grinding stones of the unit thin both sides of the blade simultaneously. The operator checks the blade thickness with a built-in gauge to determine if it has been sufficiently thinned. After thinning, the honing/edging stones apply a beveled edge on both sides of the blade simultaneously. The blade bevel angle can be adjusted as needed.

The HE2's cast aluminum body is housed under a durable, easy-to-clean, fiberglass cover. Though the HE2 can be used as a tabletop grinder, an optional cart with casters allows portability.

For a precise cutting edge every time, trust the proven HE2 sharpening system from Cozzini.

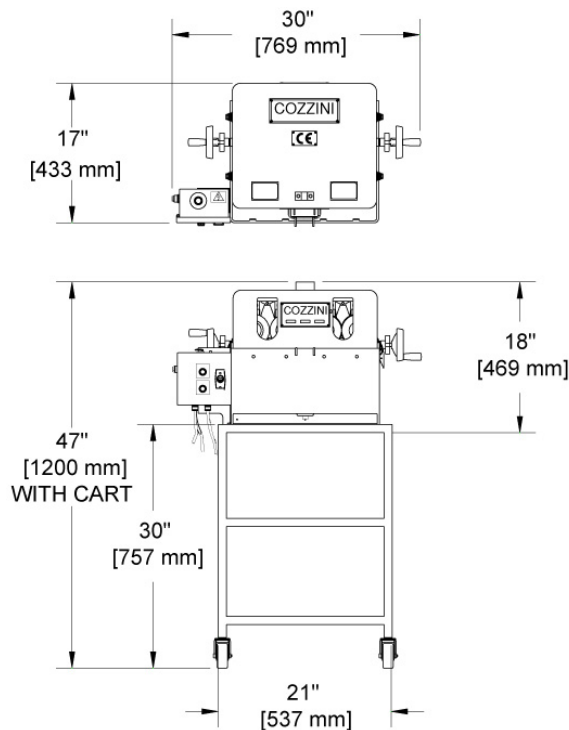

HE2 KNIFE SHARPENING SYSTEM			
Voltage	Frequency	HP	kW
115 V	50 or 60 Hz	1	.75
220 V		3/4	.56

10/05 E

WORLD HEADQUARTERS Cozzini, Inc.
4300 West Bryn Mawr Avenue Chicago, IL 60646-5943 U.S.A.

COZZINIGROUP
COMPLETE FOOD EQUIPMENT SOLUTIONS

WORLDWIDE REPRESENTATION | 773.478.9700 | COZZINI.COM | SALES@COZZINI.COM