

PRIMEEDGE • ERGO STEEL II



PRIMEEdge®

COZZINI CUTTING EDGES
AND SHARPENING SOLUTIONS



Bench mounted



Hand-held option

ERGO STEEL II

- Perfect edge in seconds.
- Aligns both sides of the blade simultaneously.
- Straightens and prolongs the edge life of hand knives.
- Ideal for all types of small and large knives.
- Can be bench mounted or hand held.
- Optional handle for hand held operation can be attached for left or right hand use.
- Totally enclosed, sanitary spring mechanisms.
- Easy maintenance and cleaning.
- USDA and CE approved.

FOOD
PROCESSING
BLADES

EDGE
MAINTENANCE
TOOLS

SHARPENING
SYSTEMS

SHARPENING
SERVICES

PRIMEEdge®
COZZINI CUTTING EDGES
AND SHARPENING SOLUTIONS

PRIMEDGE • ERGO STEEL II

Whether you process chicken, beef, pork or fish, keeping knife edges sharp is essential on the processing line. With use, sharp knives will dull. The Cozzini Ergo Steel II is a fast and easy way to straighten and restore those knife edges for razor-sharp performance. The Ergo Steel II is an edge maintenance tool used on the production floor. Throughout the day, as a knife edge dulls, the operator can slide the blade through the unique spring-tensioned rods of the Ergo Steel and sharpen the edge in a matter of seconds.

The Ergo Steel II consists of a pair of pivoting, hardened stainless steel, tempered rods on a food-grade, molded polypropylene base. Under each pivoting rod, fully enclosed spring mechanisms provide perfect sharpened angle and tension between the knife edge and stainless rods. Both sides of the edge are straightened simultaneously, assuring a perfect edge in seconds.

Requires no training to use, the Ergo Steel II can be mounted on a tabletop beside each worker, or can be hand-held with the optional handle (HES-2H) for left or right hand operation.

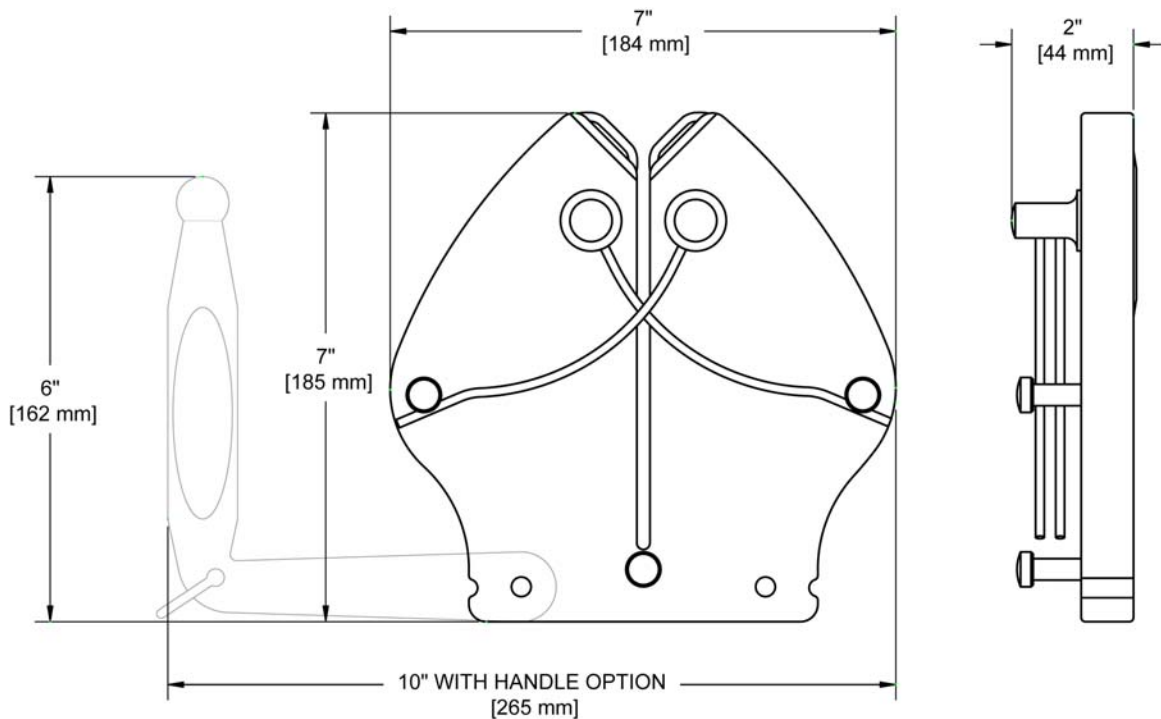

ERGO[®]
STEEL II

When ordering Ergo Steel II specify **Model No. HES-2**
Optional handle: HES-2H

3/06 E

WORLD HEADQUARTERS Cozzini, Inc.
4300 West Bryn Mawr Avenue Chicago, IL 60646-5943 U.S.A.

COZZINIGROUP
COMPLETE FOOD EQUIPMENT SOLUTIONS

WORLDWIDE REPRESENTATION | 773.478.9700 | COZZINI.COM | SALES@COZZINI.COM