

BELT CONVEYOR



PrimeMove™
COZZINI MATERIAL HANDLING SYSTEMS

BELT CONVEYOR

- Horizontal, inclined, turning, or in-line metal detector style conveyors in custom sizes.
- Horizontal feed and discharge options available.
- Choice of hydraulic or electric drive.
- Hinged or removable sides.
- Quick-release take-up design raises belt for easy cleaning of conveyor bed and belt.
- Variety of sanitary bearing designs available.
- Wide range of belt designs: solid, interlocking and wire.
- USDA accepted and CE approved. Built in conformity with AMI sanitary equipment design principles.

BELT CONVEYOR

Cozzini knows that reliable material handling is a critical part of your overall process. That is why Cozzini Belt Conveyors (CBC) are custom-made to meet your demanding production requirements. Choose from a multitude of belt widths, drive speeds, and belt styles. Optional casters allow portability.

Sanitation and cleanability are just as important. Drain-through or solid interlocking belts, quick release take-ups, washdown duty motors, and removable sides and wear strips make the CBC series a standalone among other belt conveyor designs.

Stainless steel construction with fine sanitary finish throughout, and smooth-ground welds in all product contact zones ensure utmost sanitation and ease of washdown and inspection.

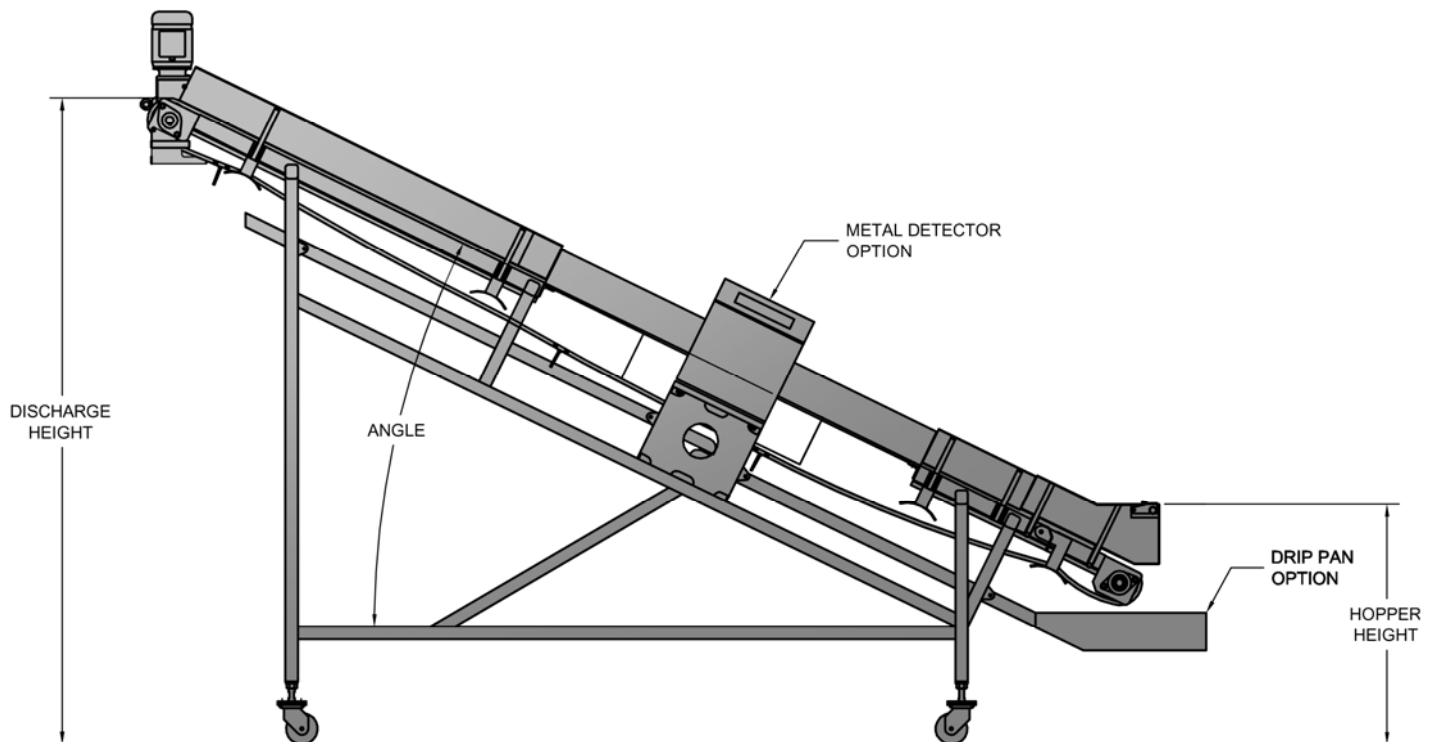

9/05 E

WORLD HEADQUARTERS Cozzini, Inc.
4300 West Bryn Mawr Avenue Chicago, IL 60646-5943 U.S.A

COZZINIGROUP
COMPLETE FOOD EQUIPMENT SOLUTIONS

WORLD REPRESENTATION • 773 478-9700 • www.cozzini.com • sales@cozzini.com